

Variability in Icelandic agreement: An interaction of DP licensing and Multiple Agree¹

Cherlon Ussery

Carleton College

1. Introduction and Overview of Agreement in Icelandic

This paper explores verbal agreement patterns in Icelandic. In general – in Icelandic and cross-linguistically – verbs agree with Nominative DPs. As shown in the Icelandic sentence in (1), the verb ‘look forward to’ agrees in person and number with the Nominative subject.

- (1) Við hlökkum/*hlakkar til jólanna.
we.Nom.1pl look forward.1pl/*3sg to Christmas.the
‘We look forward to Christmas.’² (based on Sigurðsson 2009, EX 36)

However, case and agreement do not always pattern together. In Icelandic constructions with Dative subjects and Nominative objects, (and embedded Nominative subjects), there is optionality in agreement, but not in case. In (2), the verb ‘like’ either agrees with the Nominative object ‘money’ or it appears in the default third singular form.³ By contrast, the object is necessarily Nominative.

- (2) Mörgum stúdentum líka/líkar peningarnir/*peningana.
many students.Dat like.3pl/3sg money.the.Nom.pl/*Acc.pl
‘Many students like the money.’

This paper provides an account of the type of agreement optionality found in constructions such as (2). I present data reported in Ussery (2009) which suggest that the

¹I owe a great deal of thanks to the following people for invaluable feedback on the ideas and proposal presented here: Rajesh Bhatt, James Cathey, Lyn Frazier, Lisa Green, Kyle Johnson, Andrew McKenzie, Peggy Speas, Ellen Woolford, and audiences at NELS 40 and the 84th Annual LSA Meeting. Special thanks to Jóhannes Gísli Jónsson, Þórhallur Eypórsson, Matthew Whelpton, and students at the University of Iceland for assistance with data collection. All errors are, of course, mine.

²In some varieties/registers, a Dative subject may be used with the verb *hlakka til* ‘look forward to’, in which case the verb appears in the default (third singular) form.

³For arguments that the Dative in constructions such as (2) is a subject, see Jónsson (1996, 2003), Sigurðsson (2004), Thráinsson (2007), Zaenen, Maling, and Thráinsson (1985), among others.

rate of agreement is systematic and varies according to the type of construction. Based on a survey of sixty-one native Icelandic speakers, the rate of agreement in constructions such as (2) is 47%.⁴ As is well known, Icelandic allows transitive expletive constructions (see Bobaljik and Jonas 1996 for discussion). The sentence in (3) is the transitive expletive counterpart to (2), and the rate of agreement in such constructions is 36%.

- (3) Það líka/líkar mörgum stúdentum peningarnir.
 there like.3pl/3sg many students.Dat money.the.Nom.pl
 ‘There like many students the money.’

In bi-clausal constructions with matrix Dative subjects and embedded Nominative subjects, there is also a disparity between non-expletive and expletive constructions. In constructions such as (4) the rate of agreement is 36%, while agreement occurs 18% of the time in the expletive counterpart in (5).

- (4) Einum dómara sýndist/sýndust þessar athugasemdir vera óréttlátar.
 one judge.Dat.sg understood.3sg/3pl these comments.Nom.pl to be unfair
 ‘One judge understood these comments to be unfair.’
- (5) Það sýndist/sýndust einum dómara þessar athugasemdir vera óréttlátar.
 expl understood.3sg/3pl one judge.Dat.sg these comments.Nom.pl be unfair
 ‘There understood one judge these comments to be unfair.’

The agreement patterns discussed in this paper are summarized in (6).

(6) Agreement Across Constructions

Word Order	Agreement	
<i>Mono-clauses</i>		
Dat-verb-Nom	47%	p < .05
Expl-verb-Dat-Nom	36%	
<i>Bi-clauses</i>		
Dat-verb-[_{TP} Nom...]	36%	p < .05
Expl-verb-Dat[_{TP} Nom...]	18%	

The above patterns are intriguing for three reasons. First, in the standard account of case and agreement (Chomsky 2000), both types of features are determined simultaneously via the same Agree relation. On this account, the asymmetry illustrated by obligatory Nominative case assignment and optional agreement is unexpected. Second, while optionality in long-distance agreement (LDA) is widely attested, optionality in monoclausal constructions is not as widespread. There are two general approaches to accounting for LDA. The first approach involves restructuring, in which it is argued that the complement clause lacks some degree of functional structure, and therefore, does not constitute an independent domain.⁵ Optionality is derived from the proposal that the verb

⁴The survey (a forced-choice task) was conducted in September 2008. Participants were students at the University of Iceland. Speakers were given sentences displaying the default and agreeing forms of verbs and asked to select which form they would likely use in casual conversation.

⁵ See, for instance, Bhatt (2005) for an analysis of LDA in Hindi and Wurmbrand (2001) and Bobaljik and Wurmbrand (2005) for an analysis of LDA in German with extensions to Japanese.

selects either a full clausal complement or a restructuring complement. When a full clausal complement is selected, agreement is blocked because the verb and target DP are not in the same domain. The other type of analysis involves (overt or covert) movement of the target DP to the edge of the lower clause, thus making it sufficiently close to the probe.⁶ Neither a restructuring nor an edge-based analysis accounts for optionality in monoclausal constructions because the probe and the target DP are in the same domain. As discussed in Section 3.2, Sigurðsson and Holmberg (2008) provide an analysis of Icelandic agreement which does account for the optionality in both monoclausal and biclausal constructions. However, this analysis does not account for the third intriguing aspect of the above pattern, the fact that there is degradation in agreement across various types of constructions. To my knowledge, no other analysis provides a mechanism to account for this systematic degradation.

There are four primary components of the analysis presented in this paper. First, I argue that case and agreement are established via different probe-goal relations. I show that while the probe responsible for case is necessarily in an Agree relation with a Nominative object, the probe responsible for agreement need not be. Second, I argue that the optionality in agreement follows from the optionality of Multiple Agree and I illustrate that the default form of the verb is realized when Multiple Agree fails to apply. Third, I provide evidence that a derivation can be ruled out at the point of vocabulary insertion when there are conflicting feature values that cannot be mapped to one morphological form. Finally, I show that as the number of interveners between T and the Nominative increases, the likelihood of agreement decreases.

This paper is organized as follows: Section 2 discusses the standard account of case and agreement and presents an alternative which divorces the operations responsible for each. Section 3 outlines the proposal that Multiple Agree is optional and in doing so, also accounts for the widely-observed difference between person and number features; first and second person Nominative objects are generally not allowed in Icelandic. Section 4 accounts for the degradation in agreement shown in (6). Section 5 addresses issues raised by this proposal. Section 6 concludes.

2. The Division Between Case and Agreement

The valuation/checking of case and agreement features is generally argued to take place via the same Agree operation, which is defined in (7).

- (7) $\alpha > \beta$ Agree (α, β), where α is a probe and β is a matching goal, ‘>’ is a
 c-command relation and uninterpretable features of α and β are checked/deleted. (Chomsky 2000)

T is merged with a valued case feature [Nom] and unvalued phi features [$u\Phi$]. DPs, on the other hand, are merged with an unvalued case feature [$uCase$] and valued phi features – e.g. [person=1], [person=2], [number=pl]. (I assume that third person DPs lack a person value and singular DPs lack a number value.) When T values [$uCase$] on a DP, that same DP values [$u\Phi$] on T. By contrast, when T does not value [$uCase$] on a DP, that DP cannot value [$u\Phi$]. Since T assigns Nominative, the derivation in (8)a correctly delivers

⁶ See, for instance, Polinsky and Potsdam (2001) for an analysis of LDA in Tsez.

agreement in (1). Since T does not assign Dative⁷, the derivation in (8)b correctly delivers the default verbal form, illustrated in (9).

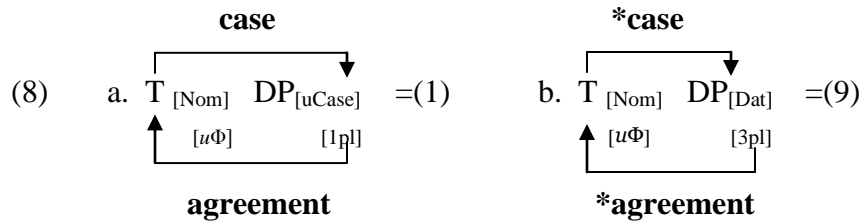

- (9) Stelpunum leiddist/*leiddust.
 girls-the.Dat.pl bored.3sg/*3pl
 ‘The girls felt bored.’

The standard account becomes problematic when we consider the constructions in which there is optionality in agreement, but not in case: case and agreement *should* pattern the same way and neither should be optional.

The first part of my proposal involves arguing for a division between case and agreement. I propose that [Nom] and [uΦ] are separate probes on T and probe independently. When [Nom] and [uΦ] are in an Agree relation with the same goal, there is agreement with the Nominative, as shown in (10)a. In the derivation in (10)b, on the other hand, [Nom] probes the object DP, while [uΦ] does not. Consequently, the object bears Nominative case but the verb appears in the default form.



Evidence for some division between case and agreement comes from other asymmetries. Samek-Lodovici (2003) observes that the degree to which a subject triggers agreement is sometimes dependent on the surface position of the subject. For instance, in Standard Arabic, finite verbs agree in person, gender, and number with pre-verbal subjects. However, verbs agree in person and gender only with post-verbal subjects.⁸ Given that Nominative subjects have their case valued by T (or by the [Nom] probe on the present proposal) irrespective of whether they move out of the vP, we do not expect agreement to be sensitive to the position of the DP, while case is not. Other case-agreement asymmetries have been noted by Bhatt (2005) and Woolford (2006b), in particular. In his analysis of LDA in Hindi-Urdu, Bhatt (2005) argues that a DP that has its case valued by one probe can value [uΦ] on a different probe. Woolford (2006b)

⁷ I assume that Dative is valued by v_{Dat} . (See McFadden 2004/2006, Woolford 2006a, among others, for discussion.)

⁸ (i) L-banaat-u darab-na / *-at 1-ʔ awlaad-a *Pre-verbal subject: Full Agreement*
 the-girls-Nom hit-past-3fem.pl./*3fem.sg the-boys-Acc
 ‘The girls hit the boys.’

(ii) Darab-at / *-na ʔal-banaat-u Zayd-an *Post-verbal subject: Partial Agreement*
 hit-past-3fem.sg / *3fem.pl the-girls-Nom Zayd-Acc
 ‘The girls hit Zayd.’ (Samek-Lodovici 2003)

proposes that when Nominative is not valued on a DP, it may be deleted from T while [$u\Phi$] may remain active and be valued by a non-Nominative DP.

3. Accounting for Optionality

3.1 The Optionality of Multiple Agree

Under the standard conceptualization of Agree, there is a one-to-one relationship between probe and goal. Multiple Agree (Hiraiwa 2001), on the other hand, allows for a probe to be in an Agree relation with more than one goal. As mentioned above, Bhatt (2005) makes a similar proposal that allows for a goal to be in an Agree relation with more than one probe. I also adopt a one-to-many approach and I build on Hiraiwa's (2001) proposal by arguing that Multiple Agree is an optional operation. Following a principle of Relativized Minimality (Rizzi 1990, 2001), I assume that a probe necessarily enters into an Agree relation with the closest DP which potentially bears the relevant matching values. However, a probe does not necessarily enter into an Agree relation with any goal that is not the closest one. In essence, a single application of Agree, as shown in (11)a is obligatory, while multiple applications of Agree, as shown in (11)b, are optional.

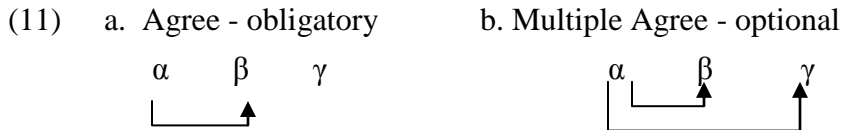

Under this proposal, [$u\Phi$] necessarily probes a Dative subject, as the Dative is the closest DP to T. Since Multiple Agree is optional, [$u\Phi$] only optionally probes past the Dative in order to Agree with the Nominative. It should be noted that [Nom] also obligatorily probes the Dative, and optionally probes past the Dative to value Nominative on the object. Since a DP cannot have an unvalued case feature, the only grammatical derivation is one in which [Nom] probes both DPs. For the remainder of this paper, I assume a derivation in which [Nom] enters into a Multiple Agree relation and I discuss only the optionality related to [$u\Phi$] probing.

3.2 The Division Between Person and Number

The proposal that Multiple Agree is optional has the additional benefit of accounting for the difference between person and number features in Icelandic. As in many languages, Icelandic restricts the contexts in which first and second person DPs may appear. Icelandic constructions with [1]/[2] Nominative objects are (usually) ungrammatical, as shown in (12). Conversely, there is no number restriction on Nominative objects, as these DPs can be singular or plural.

- (12) *Henni leiddist við/pið.
her.Dat bored.3sg we.Nom.pl/you.Nom.pl
‘She found us/you boring.’

Many accounts of Icelandic agreement differentiate between person and number features. For instance, Alexiadou (2003) proposes that Tense checks Person, while Aspect checks Number. Anagnostopoulou (2005) and Taraldsen (1995) propose that Datives value Person, but not Number, on T. The idea that Person is privileged with respect to Number is particularly evident in Sigurðsson and Holmberg's (2008) proposal,

Variability in Icelandic Agreement

grammatical. I propose that derivations such as (16) are ruled out at the point of vocabulary insertion because all of the values for [Φ] cannot be realized.

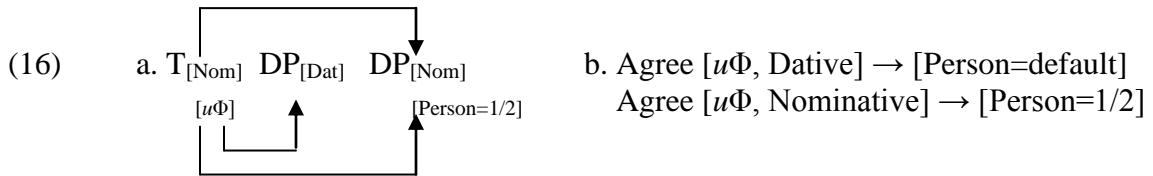

Following Anagnostopoulou (2005) and Taraldsen (1995), I assume that Datives value [$u\Phi$] to a default person value. Because [$u\Phi$] is valued to default by the Dative and to [1]/[2] by the Nominative, in order to insert a vocabulary item at the point of morphological spell-out, there must be a form which realizes these different values. Absent such a form, the derivation cannot be morphologically realized. In essence, (16) is syntactically licit, but is ineffable.

This proposal predicts that if there is a way to realize all of the values for [Φ] that result from the Multiple Agree relations, constructions with [1]/[2] Nominative objects should be grammatical. This prediction is, indeed, confirmed. In cases where the form expressing person agreement and the form expressing default person are syncretic, a [1]/[2] Nominative object is allowed. In (17), both the 3rd singular and the 1st singular forms for ‘bored’ are *leiddist*.

- (17) Henni leiddist ég.
 her.Dat bored.1sg/3sg I.Nom.1sg
 ‘She found me boring.’ (Sigurðsson 1996:33)

When the Multiple Agree derivation shown in (16) applies to (17), [$u\Phi$] is valued to [Person=default, 1]. Since *leiddist* realizes both values, the derivation is not ruled out at the point of vocabulary insertion. It should be noted that since person values must be checked, the only grammatical derivation for (17) is the one in (16).

The idea that Multiple Agree induces a feature clash is also found in Anagnostopoulou’s (2005) account, which argues for a unified analysis of the person restriction in Icelandic and the Person Case Constraint effect found in many languages (see Bonet 1991 for discussion).¹⁰ The crux of Anagnostopoulou’s (2005) proposal is that a feature clash arises when the same functional head checks Person and Number against different goals. On this account, in Icelandic, T checks Person against the Dative and the Dative values Person to [default].¹¹ Anagnostopoulou (2005) assumes that the number values of DPs bearing non-structural case are not accessible to T. Therefore, in order for T to value Number, it must probe the object. If the object bears [1]/[2], the derivation crashes, in part, because Person already has a [default] value.

¹⁰ Icelandic does not display a person restriction in the canonical ditransitive PCC environments. In Icelandic double object constructions, the indirect and direct objects may be first or second person. I leave open the question of whether there can be a unified account of the PCC and the Icelandic person restriction.

¹¹ Anagnostopoulou (2005) assumes a relationship between EPP and Person. Therefore, the Dative checks Person because of its EPP relation with T.

There are two crucial differences between my proposal and Anagnostopoulou's (2005). On my account, conflicting feature values lead to ineffability at the point of vocabulary insertion, not ungrammaticality. While my account predicts the grammaticality of (17), Anagnostopoulou's (2005) account does not. The second difference relates to the relationship between case and agreement. The crucial assumption on Anagnostopoulou's (2005) account is that structural case is assigned only when there is complete checking of phi features. A Nominative object bearing a person value cannot have this value checked by T, since Person is valued to [default] by the Dative subject. Since only the number value on the object could be checked, the DP cannot receive Nominative. Therefore, constructions such as (12) crash not only because of a feature clash, but also because the object cannot get case. The argument that structural case is assigned only when there is complete phi checking is motivated, in part, by the idea that "[number] agreement with Nominative objects is by and large obligatory" (Anagnostopoulou 2005:209). Since third person DPs do not have a person value, there is no feature clash and Nominative is assigned when T checks Number. However, given the pattern in (6), non-agreement is consistently preferred in Dative-Nominative constructions, suggesting that case is not dependent on complete phi-checking. On my proposal, Number need not be checked and, thus, the optionality in number agreement can be accounted for.

[1]/[2] Embedded Nominative Subjects

Embedded Nominative subjects can bear [1]/[2] values, but they do not (usually) agree, as shown in (18).

- (18) Honum mundi/*mundum virðast við (vera) hæfir.
 him.Dat would.3sg/*1pl seem we.Nom.pl (be) competent
 'We would seem competent to him.' (Sigurðsson and Holmberg 2008, EX 7/8a)

I propose that the Nominative in (18) is licensed because [$u\Phi$] on the embedded nonfinite T checks Person. Unlike in constructions with Nominative objects, there is no intervening Dative. Since Agree is obligatory, [$u\Phi$] on non-finite T necessarily probes the embedded Nominative.¹² Since Multiple Agree is optional, [$u\Phi$] on finite T may also probe the embedded Nominative. As with the monoclausal constructions, the Multiple Agree derivation leads to ineffability unless there is syncretism. In (18) the only allowable derivation is one in which [$u\Phi$] on finite T probes only the Dative. However, in (19) both the Agree and Multiple Agree derivations are allowed, since *virtust* realizes both the second plural and the default person plural forms.

¹² The proposal that [$u\Phi$] on non-finite T can check a person value is motivated by the fact that Icelandic has an enriched non-finite T. As is well-known, in Icelandic control constructions, non-finite T assigns Nominative (see, in particular, Sigurðsson 1991). However, it does not seem to be the case that non-finite T in Icelandic always assigns Nominative. Icelandic ECM constructions in which the matrix subject receives structural case pattern like English in that the embedded subject is Accusative, as in (iii).

(iii) Þeir telja hana heita Maríu
 they.Nom believe her.Acc be-called Mary.Acc
 'They believe her to be called Mary.' (Thráinsson 2007:168)

I, therefore, assume that [Nom] on finite T values Nominative in the embedded subject. However, having [Nom] on non-finite T value Nominative on the embedded subject is not incompatible with the analysis proposed in this paper.

- (19) Henni virtist/ virtust þið eitthvað einkennilegir.
 her.Dat.seemed.3sg/2-3.pl you.Nom.pl somewhat strange
 ‘You seemed somewhat strange to her.’

(Sigurðsson and Holmberg 2008, EX 50a)

To summarize, constructions with [1]/[2] Nominative objects are generally ungrammatical irrespective of whether Agree or Multiple Agree applies. If [$\mu\Phi$] probes only the Dative, the unchecked person value on the object leads to a syntactic crash. If [$\mu\Phi$] probes both the Dative and the Nominative, conflicting person values lead to a morphological crash, unless there is a form which realizes both [default] and the person value of the Nominative. Now that the optionality and morphological consequences of Multiple Agree have been motivated, the degradation in agreement can be accounted for.

4. Accounting for Degradation in Agreement

From this point forward, I discuss only constructions with third person Nominatives. Since these DPs do not bear a person value, they are not required to be in an Agree relation with [$\mu\Phi$] in order to be licensed. I argue that as the number of interveners between T and the Nominative increases, the likelihood of [$\mu\Phi$] probing the Nominative decreases. The constructions in (20) are sample items from the aforementioned survey and the agreement patterns summarized in (6) are repeated.

- (20) a. ¹³**Intransitive** *100% agreement*
 Það slógust/*slóst fjórir nemendur á ballinu
 there fought.3pl/*3sg four students.Nom at dance.the
 ‘There fought four students at the dance.’
- b. **Transitive** *47% agreement*
 Sumum gömlum mönnum líkar/líka pípuhattar.
 some old.Dat.pl men.Dat.pl like.3sg/3pl top hats.Nom.pl
 ‘Some old men like top hats.’
- c. **Transitive Expletive** *36% agreement*
 Það líkar/líka sumum gömlum mönnum pípuhattar.
 expl like.3sg/3pl some old men.Dat.pl top hats.Nom.pl
 ‘There like some old men top hats.’
- d. **Bi-clausal Transitive** *36% agreement*
 Einum dómara sýndist/sýndust þessar athugasemdir vera óréttlátar.
 one judge.Dat.sg understood.3sg/3pl these comments.Nom.pl be unfair
 ‘One judge understood these comments to be unfair.’
- e. **Bi-clausal Transitive Expletive** *18% agreement*
 Það sýndist/sýndust einum dómara þessar athugasemdir vera óréttlátar.
 expl understood.3sg/3pl one judge.Dat.sg these comments.Nom.pl be unfair
 ‘There understood one judge these comments to be unfair.’

¹³ Examples based on those appearing throughout Thráinsson (2007). The percentage reflects the rate of agreement for items of this particular type, not the token shown.

Unlike in the other constructions with post-verbal Nominatives, agreement is obligatory in expletive intransitives, as shown in (20)a. This fact is important because it provides additional evidence for the proposal that Multiple Agree is optional. Since Agree is obligatory, one way to account for (20)a is to assume that $[u\Phi]$ necessarily probes the Nominative. There is no Dative, thus, agreement always obtains in these constructions. Another possibility is that $[u\Phi]$ necessarily probes the closer DP, which is the expletive (see Chomsky's 2000 definition of "closeness"). Since the Nominative is the associate of the expletive, the expletive values $[u\Phi]$ to $[\text{Number}=\text{pl}]$, and there is obligatory agreement. (Of course, Multiple Agree may apply. Since the features of the expletive and the Nominative are identical, there will never be a conflict.) Evidence that $[u\Phi]$ probes the expletive comes from the fact that agreement is more degraded in the transitive expletive construction than in the regular transitive construction. In the derivation for (20)b, shown in (21)a, two Agree relations are required in order for $[u\Phi]$ to probe the Nominative. By contrast, in the derivation for (20)c, shown in (21)b, three Agree relations are required in order for $[u\Phi]$ to probe the Nominative.

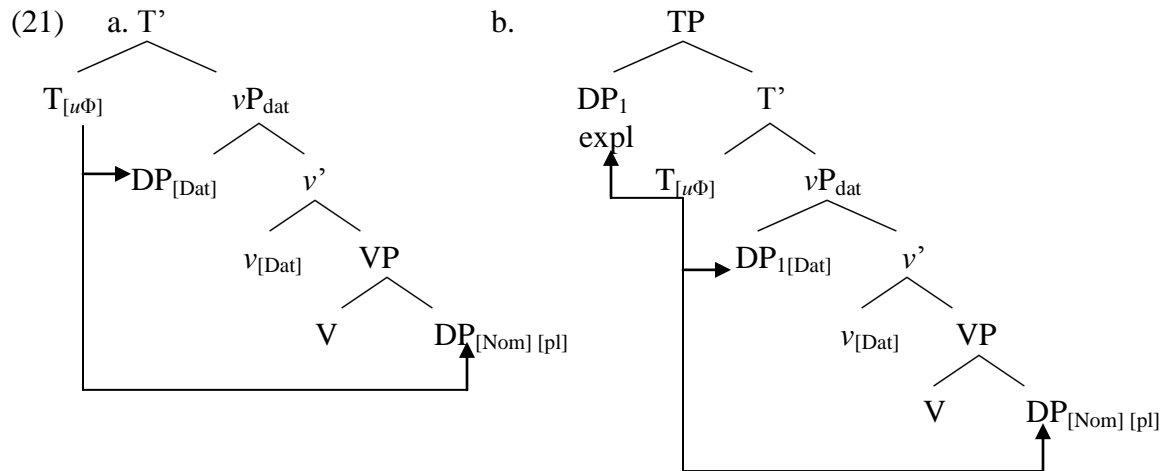

Since the Dative is the associate of the expletive in constructions such as (20)b¹⁴ and since Datives cannot value $[u\Phi]$, when $[u\Phi]$ probes only the expletive or probes the expletive and the Dative, the default form surfaces. If $[u\Phi]$ probed only its c-command domain, we would not expect a difference in the rate of agreement between (20)b and (20)c ($p < .05$), since $[u\Phi]$ would probe only the Dative and the Nominative in both derivations.

There is also a difference in agreement between the non-expletive and expletive bi-clausal constructions ($p < .05$), providing further evidence that $[u\Phi]$ probes the expletive. The derivation for (20)d is shown in (22)a, and the derivation for (20)e is shown in (22)b. In these derivations, $[u\Phi]$ probes the complement clause (Chomsky 2000, Sigurðsson and Holmberg 2008), in addition to probing the Dative and the Nominative. Consequently, in (22)a three Agree relations are required in order for $[u\Phi]$ to probe the Nominative, while in (22)b, four Agree relations are required.

¹⁴ Since only the Dative is required to be indefinite in expletive Dative-Nominative constructions, the Dative is the associate.

(iv) Það mistókst/ mistókust mörgum stúdentum allar tilraunirnar
 expl failed.3sg/3pl many.Dat students.Dat all.Nom attempts-the.Nom
 'There failed many students all the attempts.' (based on Sigurðsson 1996:ex51/52b)

Variability in Icelandic Agreement

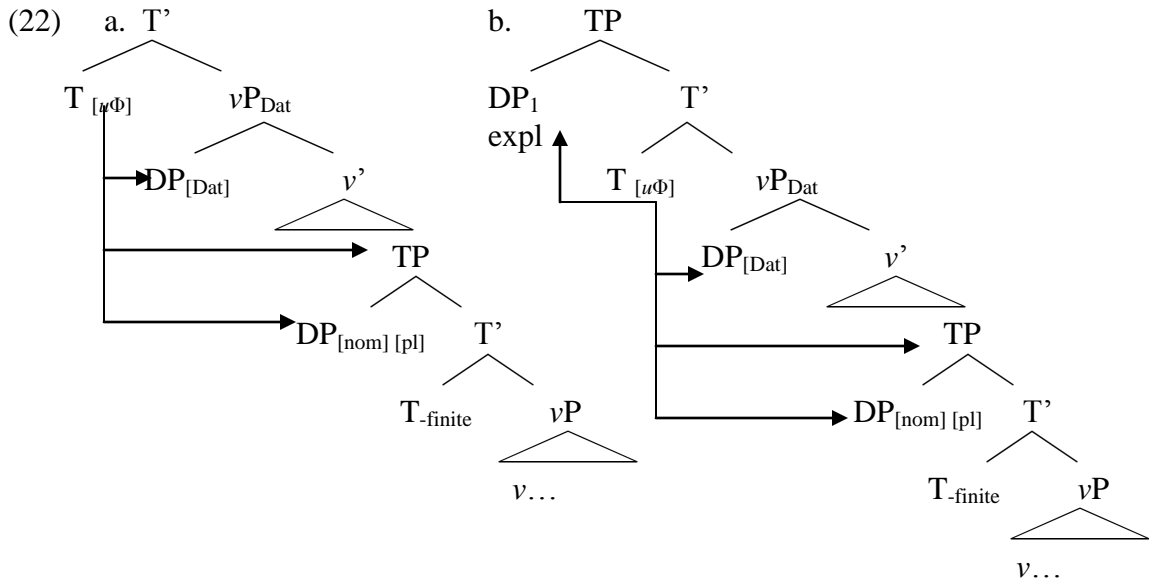

The derivations in (21)b and (22)b suggest that Agree can be established via Spec-head or under c-command. Though Chomsky's (2000) definition of Agree requires c-command, there are other examples of a head probing its specifier. In particular, non-structural case is generally assumed to be assigned in a Spec-head configuration (see Legate 2008, McFadden 2004/2006, Woolford 2006b, among others). As assumed throughout this paper, v_{Dat} assigns Dative to the DP in its specifier. While there is sufficient evidence that Agree does not require a Spec-head relationship (see, in particular Bobaljik and Wurmbrand 2005 for discussion), it seems that Agree may apply in this configuration. As such, a slightly modified definition of Agree is proposed in (23).

- (23) α β Agree (α , β), where α is a probe and β is the closest matching goal and β is in the specifier of the phrase immediately dominating α or α c-commands β . Uninterpretable features of α and β are checked/deleted.

It should be noted that $[u\Phi]$ obeys the same locality conditions as any other probe. One often-discussed contrast is that illustrated between (24), in which agreement is optional, and (25), in which agreement is not allowed. This contrast is known as the Schütze-Watanabe contrast (Schütze 1997, Watanabe 1993).

- (24) $Jóni_i$ virðast/virðist [t_i vera taldir [t_i líka hestarnir]]
 J.Dat seemed.pl/seemed.sg be believed.Nom.pl like horses.Nom.pl
 'Jon seemed to be believed to like horses.'

- (25) Mér *virðast/virðist [$Jóni_i$ vera taldir [t_i líka hestarnir]]
 Me.Dat *seemed.pl/seemed.sg J.Dat be believed.Nom.pl like horses.Nom.pl
 'I perceive Jon to be believed to like horses.' (Schütze 1997:108-109)

One notable account of this contrast is found in Bobaljik (2008). On this analysis, (24) is restructuring and (25) is non-restructuring (because there is an overt subject $Jóni$ in the lower clause). Following this proposal, on my account $[u\Phi]$ may probe the Nominative in (24) because $[u\Phi]$ and the Nominative are in the same domain. As discussed in Section 1, restructuring complements do not constitute independent domains. Although we have seen that agreement is allowed across clause boundaries, in constructions such as (21)d/e,

the Nominative is at the edge of the lower clause, and effectively, in the same domain as the higher T. The Nominative in (25), on the other hand, is not in the same domain as the matrix T.

5. Residual Issues

5.1 Defective Intervention

Another way to think about the agreement pattern in Dative-Nominative constructions is to consider the Dative a defective intervener, as argued by Holmberg and Hróarsdóttir (2003). Chomsky's (2000) definition of defective intervention, stated in (26), is meant to account for instances in which a DP that is seemingly ineligible as a goal for a particular probe interferes with the probe's ability to Agree with an eligible DP.

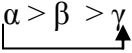
- (26) Defective Intervention Constraint (Chomsky 2000:123)
- $\alpha > \beta > \gamma$

- *AGREE (α, γ), α is a probe and β is a matching goal, and β is inactive due to a prior Agree with some other probe.
- ***

Hiraiwa's (2001) Multiple Agree proposal is formulated to avoid a defective intervention effect. Multiple goals are probed simultaneously, instead of serially. As such, no goal can block another probe-goal relation. The concept of defective intervention has been challenged in the literature (see, for instance, Bobaljik 2008 and Broekhuis 2007), in large part, because it is not clear what a defective intervener is. Considering the data presented in this paper, a defective intervention analysis poses two problems. First, given the attested agreement optionality, it would have to be that Datives – as well as expletives and complement clauses – are sometimes defective interveners and other times transparent for agreement. The bigger problem is that it is not clear how Nominative would be assigned to the object. Even though agreement is sometimes blocked, case never is. While my analysis implicitly argues against a defective intervention account, it does not distinguish between serial and simultaneous probing. On either approach, the main claim that an increase in the number of goals intervening between T and the Nominative leads to a decrease in agreement holds.

5.2 The Grammars of Individuals

The analysis argued for in this paper accounts for variability throughout a population, and ideally, an analysis which captures the grammars of individuals is needed. Sigurðsson and Holmberg's (2008) account categorizes speakers into agreement dialects. While I do not, at present, have enough data to adequately do the same, there are three patterns which emerge. First, approximately 8% (5 out of 61) of participants preferred non-agreement in all constructions. These speakers never selected the agreeing form of the verb. I take this to indicate that for these speakers, [$u\Phi$] does not enter into Multiple Agree relations.¹⁵ Crucially, since Multiple Agree is required for Nominative case assignment in these constructions, it cannot be that there is a general Multiple Agree parameter. Second, just under 12% (7 out of 61) of the participants allowed agreement in Dative-verb-Nominative constructions only, e.g., (20)b. I take this to indicate these speakers allow [$u\Phi$] to probe only two goals. Third, approximately 28% (17 out of 61) of

¹⁵ In retrospect, it would have perhaps been more informative to ask speakers to rate the acceptability of constructions exhibiting agreement and those not exhibiting agreement. This would have allowed for clearer conclusions to be drawn about which derivations speakers actually allow.

participants allow agreement in bi-clausal expletive constructions, e.g. (20)e). This suggests that for these speakers Multiple Agree is allowed to apply freely (though [$u\Phi$] obeys the locality conditions discussed in Section 4). Crucially, though, only two speakers in this category consistently prefer agreement in this type of construction, underscoring the optionality of Multiple Agree. Even speakers who freely allow Multiple Agree do so only optionally.

6. Conclusion

While I have proposed that case and agreement are established via different operations, it is important to note that this proposal still captures the fact that case and agreement usually pattern together. In most constructions, the DP in Spec, ν P is assigned structural case. Since this DP is closest to T, [Nom] and [$u\Phi$] necessarily probe the subject, and the pattern of obligatory agreement with Nominative subjects emerges.

One remaining question raised by this proposal relates to the role of optionality within a Minimalist framework. Given the desire to constrain operations, the proposed optionality of Multiple Agree may be a less than optimal solution. However, given the strong empirical evidence that agreement is optional, I leave for future research the question of whether an optional operation is actually antithetical to Minimalist principles.

References

- Alexiadou, Artemis. 2003. On nominative case features and split agreement. In *New Perspectives on Case Theory*, ed. by E. Brandner & H. Zinnsmeister, 23-52. Stanford, CA: CLSI.
- Anagnostopoulou, Elena. 2005. Strong and weak person restrictions: a feature checking analysis. In *Clitics and Affix Combinations*, ed. by Lorie Heggie and Francisco Ordonez, 199-235. Amsterdam: John Benjamins.
- Bhatt, Rajesh. 2005. Long distance agreement in Hindi-Urdu. *NLLT* 23:757–807.
- Bobaljik, Jonathan and Dianne Jonas. 1996. Subject Positions and the Roles of TP. *LI* 27(2):195-236.
- Bobaljik, Jonathan. 2008. Where's phi? Agreement as a post-syntactic operation. In David Adger, Susana Béjar, and Daniel Harbour, eds., *Phi-Theory: Phi features across interfaces and modules*. Oxford University Press.
- Bobaljik, Jonathan and Susi Wurmbrand. 2005. The domain of agreement. *NLLT* 23(4): 809-865.
- Broekhuis, Hans. 2007. Does defective intervention exist? *Linguistics in the Netherlands* 24(1):49-61.
- Chomsky, Noam. 2000. Minimalist inquiries: the framework. In R. Martin, D. Michaels, and J. Uriagereka, eds., *Step by step: essays on minimalist syntax in honor of Howard Lasnik*, 89-155. Cambridge, MA: MIT Press.
- Hiraiwa, Ken. 2001. Multiple agree and the defective intervention constraint in Japanese. In Ora Matsushansky et. al., eds., *The Proceedings of the MIT-Harvard Joint Conference (HUMIT 2000)* 40: 67-80. Cambridge, MA: MITWPL.
- Holmberg, Anders and Thorbjörg Hróarsdóttir. 2003. Agreement and movement in Icelandic raising constructions. *Lingua* 113:997-1019.
- Jónsson, Jóhannes Gíslí. 1996. Clausal architecture and case in Icelandic, Ph.D. Dissertation, University of Massachusetts, Amherst, MA. [Distributed by GLSA].

- Jónsson, Jóhannes Gísli. 2003. Not so quirky: On subject case in Icelandic. In E. Brandner and H. Zinsmeister, eds., *New Perspectives on Case and Case Theory*, 127-164. Stanford, CA: CSLI Publications.
- Legate, Julie Anne. 2008. Morphological and abstract case. *LI* 39(1):55-101.
- McFadden, Thomas. 2004. The position of morphological case in the derivation: a study on the syntax-morphology interface. Doctoral dissertation, University of Pennsylvania, Philadelphia, PA.
- McFadden, Thomas. 2006. Default case and the status of compound categories in Distributed Morphology. In *Proceedings of the 30th annual Penn Linguistics Colloquium*. Available at <http://ling.auf.net/lingBuzz/000323>.
- Polinsky, Maria and Eric Potsdam. 2001. Long distance agreement and topic in Tsez. *NLLT* 19.3:583-646.
- Rizzi, Luigi. 1990. *Relativized Minimality*. Cambridge, MA: MIT Press.
- Rizzi, Luigi. 2000. *Comparative Syntax and Language Acquisition*. London: Routledge.
- Samek-Lodovici, Vieri. 2003. Agreement Impoverishment under Subject Inversion – A Cross-linguistic Analysis. In G. Fanselow, and C. Féry, eds., *Resolving Conflicts in Grammar*. Linguistische Berichte Sonderheft 11:49-82.
- Schütze, Carson. 1997. Infl in child and adult language: agreement, case and licensing. Doctoral dissertation, MIT, Cambridge, MA.
- Sigurðsson, Halldór Ármann. 2004. Icelandic Non-Nominative Subjects: Facts and Implications. In Peri Bhaskararao and K.V. Subbarao (eds), *Non-Nominative Subjects 2*, pp. 137-159. Amsterdam: John Benjamins.
- Sigurðsson, Halldór Ármann. 2009. Remarks on features. In Kleanthes K. Grohmann, ed., *Explorations of Phase Theory: Features and Arguments*, 21-52. Berlin:Mouton de Gruyter.
- Sigurðsson, Halldór Ármann and Anders Holmberg. 2008. Icelandic dative intervention: person and number are separate probes. In Robertda D'Alessandro, ed. *Agreement Restrictions*, 251-280. Berlin:Mouton de Gruyter.
- Taraldsen, Knut Tarald. 1995. On agreement and nominative objects in Icelandic. In H. Haider, S. Olsen, and S. Vikner, eds., *Studies in Comparative Germanic Syntax*. Kluwer: Dordrecht, 307–327.
- Thráinsson, Höskuldur. 2007. *The Syntax of Icelandic*. Cambridge: Cambridge University Press.
- Ussery, Cherlon. 2009. *Optionality and Variability: Syntactic Licensing Meets Morphological Spell-Out*. Doctoral dissertation, University of Massachusetts, Amherst, MA.
- Watanabe, Akira. 1993. AGR-Based Case Theory and its Interaction with the A-Bar System, Doctoral dissertation, MIT, Cambridge, MA.
- Woolford, Ellen 2006a. Lexical case, inherent case, and argument structure. *LI* 37(1): 111-130.
- Woolford, Ellen 2006b Case-Agreement Mismatches. In Cedric Boeckx ed. *Agreement Systems*, 317-339. John Benjamins.
- Zaenen, Annie, Joan Maling, and Höskuldur Thráinsson. 1985. Case and grammatical functions: the Icelandic passive. *NLLT* 3(4):441-483.