

# Case and Phi Features as Probes

Cherlon Ussery  
Carleton College

## 1. Introduction: The Story of Case and Agreement\*

This paper uses a variety of case and agreement phenomena to argue for a reformulation of Agree (Chomsky 1995, 2000, 2001). I show that the case and phi features on T can behave independently, and do not necessarily constitute an indivisible feature bundle. As such, I argue that the case and phi features are independent probes on T. Additionally, I provide evidence that both case and agreement features can be checked either in a Spec-head configuration or under c-command, and I propose a revised Agree operation which allows for a probe-goal relationship to hold in either configuration.

The sentence in (1) illustrates verbal agreement in Icelandic. The verb agrees in person and number with the Nominative subject.

- (1) a. Við tókum/\*tekur bókina.          b. Þið takið/\*tekur bókina.  
    we.Nom take.1pl/\*3sg book.the.Acc      you.Nom.pl take.2pl/\*3sg book.the.Acc  
    ‘We take the book.’                      ‘You take the book.’      (Sigurðsson 2006)

There have been various proposals throughout syntactic literature that account for the assignment of case and agreement features. Chomsky (1991) proposes that different projections are responsible for the two types of features. Nominative case is assigned when a DP moves to Spec,TP/IP, while agreement is established when a DP moves to Spec,AgrSP. This proposal is based on the assumption that features are checked in a strictly local specifier-head configuration. However, there is evidence that feature-checking need not force movement to a specifier. As articulated in Bobaljik and Wurmbrand 2005 and Wurmbrand 2006, case assignment does not require movement to a specifier. In the Icelandic sentence in (2)a, the negation necessarily scopes over the Nominative subject. Thus, this sentence means that “It is not the case that many students have been here.” It could be that some students have been here. If the subject DP had covertly moved to Spec,TP for Nominative case assignment, then the interpretation in which the Nominative scopes over the negation should be available. However, this sentence cannot mean “As for many students, those students have not been here.” Likewise, in (2)b, the Nominative ‘some applicants’ cannot bind the reciprocal ‘each other’. If ‘some applicants’ had moved covertly to Spec,TP, it would c-command the reciprocal and we would expect the binding relationship to hold.

- (2) a. Þess vegna hafa ekki verið margir nemendur hér.  
    therefore have not been many students.Nom here  
    ‘Therefore, not many students have been here.’  
    b. \*Þess vegna virðast [að mati hvers annars] vera einhverjir umsækjendur hæfir.  
    therefore seem to judgment each other to.be some.Nom applicants.Nom qualified  
    ‘Therefore, some applicants seem to be competent in each other’s opinion.’  
    (Wurmbrand 2006:14, modified from Jónsson 1996)

As proposed by Chomsky (1995, 2000, 2001), Agree, defined in (3), divorces feature checking from movement. The two items in an Agree relation – the probe and the goal – must be in a c-command relation, but the goal need not move to the specifier of the probe’s projection.

---

\* I owe a great deal of thanks to the following people for invaluable feedback on the ideas and proposal presented here: Rajesh Bhatt, James Cathey, Lyn Frazier, Lisa Green, Kyle Johnson, Andrew McKenzie, Aynat Rubinstein, Peggy Speas, Ellen Woolford, and audiences at NELS 40, the 84<sup>th</sup> Annual LSA Meeting, and WCCFL 29. Special thanks to Jóhannes Gísli Jónsson, Þórhallur Eyþórsson, Matthew Whelpton, and students at the University of Iceland for assistance with collecting Icelandic data. All errors are, of course, mine.

- (3)  $\alpha > \beta$   
 Agree ( $\alpha, \beta$ ), where  $\alpha$  is a probe and  $\beta$  is a matching goal, '>' is a c-command relation and uninterpretable features of  $\alpha$  and  $\beta$  are checked/deleted. (Chomsky 2000)

Of course, a goal *may* move to a specifier position. A subject, for instance, may move to Spec, TP for EPP. Crucially, however, Agree does not force this movement.

Agree has the additional benefit of accounting for the general relationship between case and agreement. As has been noted by several researchers (Legate 2008, Woolford 2006, among others) verbs tend to agree with Nominative DPs in Nominative-Accusative case systems and with Absolutive DPs in Ergative-Absolutive case systems. For instance, in the Icelandic sentence in (4), the verb agrees with the Nominative object, just as the verb agrees with the Nominative subject in (1). Likewise, in Gujarati the verb agrees with the Absolutive subject in (5)a, and with the Absolutive object in (5)b.

- (4) Mér líkuðui þessar hugmyndir. *Icelandic*  
 me.Dat liked.3pl these ideas.Nom  
 'I liked these ideas.'

- (5) a. Sudha awy-i. b. Sudha-e radio khæridy-o *Gujarati*  
 Sudha(fem).Abs came-fem Sudha(fem)-Erg radio(masc).Abs bought-masc  
 'Sudha came.' 'Sudha bought a radio.'  
 (Woolford 2006b, EX 38c/39, in Mistry 1976)

The standard account is that case and agreement are assigned under c-command via the same Agree operation. T is merged with a valued case feature [Nominative] and unvalued phi features [ $u\Phi$ ]. DPs, on the other hand, are merged with an unvalued case feature and valued phi features. The probe, T, values the case of a DP goal with an unvalued case feature and, in turn, that DP values the phi features on T. Since T is also in a Agree relation with V, the verb displays the phi features of the DP to which T assigns case. T, then, mediates the relationship between the Nominative DP and the verb. This analysis can be extended to Ergative-Absolutive systems. Assuming that Nominative and Absolutive are both assigned by T (see Legate 2008 Woolford 2006 a/b for discussion), the Icelandic sentences in (1) and (4) and the Gujarati sentences in (5) can be accounted for with the same analysis, as shown in (6)a.

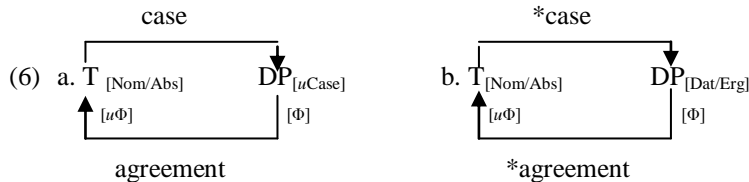

As shown in (6)b, when T does not value [ $uCase$ ] on a DP, that DP cannot value [ $u\Phi$ ] on T. This is precisely what we see in both Icelandic and Gujarati. While Nominative/Absolutive is assigned by T, an Ergative or Dative DP is assigned case by a  $v$  head specified for that case value (see Legate 2008, McFadden 2004/2006, and Woolford 2006a for discussion). As such, in (5)b, the verb does not agree with the Ergative DP, and in the Icelandic sentence in (7), the verb does not agree with the Dative.

- (7) Stelpunum leiddist/\*leiddust. *Icelandic*  
 girls.the.Dat.pl bored.3sg/\*3pl  
 'The girls felt bored.'

The prediction, therefore, is that case and agreement should necessarily pattern together: verbs should agree with DPs that are in a case relationship with T. In the following sections I show that this prediction is not necessarily borne out. A DP that has its case valued by T does not necessarily value the phi features on T. Conversely, a DP that does not have its case valued by T may value the phi features on T. Additionally, individual agreement features may behave differently. I show that some phi features on T may be valued in one structural configuration but go unvalued in a different configuration.

## 2. The Independence of Case and Agreement: Degraded Agreement in Icelandic

In Ussery 2009/2011 I provide an analysis of Icelandic constructions with Dative subjects and Nominative objects or embedded Nominative subjects. While agreement is obligatory in constructions with Nominative subjects, such as in (1), agreement is optional in Dative-Nominative constructions such as (4). Based on the results of a survey of sixty-one native Icelandic speakers, the rate of agreement varies according to the type of Dative-Nominative construction, as shown in (8).

- (8) a. **Transitive** 47% agreement  
 Sumum gömlum mönnum líkar/líka pípuhattar.  
 some old men.Dat.pl like.3sg/3pl top hats.Nom.pl  
 ‘Some old men like top hats.’
- b. **Transitive Expletive** 36% agreement  
 Það líkar/líka sumum gömlum mönnum pípuhattar.  
 expl like.3sg/3pl some old men.Dat.pl top hats.Nom.pl  
 ‘Some old men like top hats.’
- c. **Biclausal Transitive** 36% agreement  
 Einum dómara sýndist/sýndust þessar athugasemdir vera óréttlátar.  
 one judge.Dat understood.3sg/3pl these comments.Nom.pl be unfair  
 ‘One judge understood these comments to be unfair.’
- d. **Biclausal Transitive Expletive** 18% agreement  
 Það sýndist/sýndust einum dómara þessar athugasemdir vera óréttlátar.  
 expl understood.3sg/3pl one judge.Dat these comments.Nom.pl be unfair  
 ‘One judge understood these comments to be unfair.’

I argue that the case and phi features on T probe independently. While [Nom] necessarily probes the object/embedded subject (by the Case Filter), [ $u\Phi$ ] only optionally does so. Therefore, for each sentence in (8), there are two possible derivations, one in which both [Nom] and [ $u\Phi$ ] probe the Nominative DP and another in which only [Nom] probes the DP. As illustrated in (9)a, when both [Nom] and [ $u\Phi$ ] probe the DP, the verb is spelled out with agreement morphology. However, when [ $u\Phi$ ] fails to probe the Nominative DP, the verb is spelled out with the default third person singular form, as illustrated in (9)b.



Crucially, the more interveners there are between T and the Nominative, the less likely [ $u\Phi$ ] is to probe the Nominative, accounting for the systematic degradation in agreement. The derivations for the sentences in (8) are shown in (10).

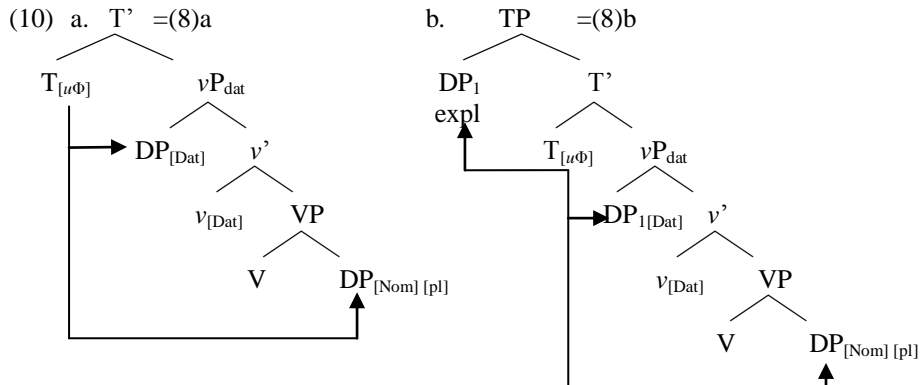

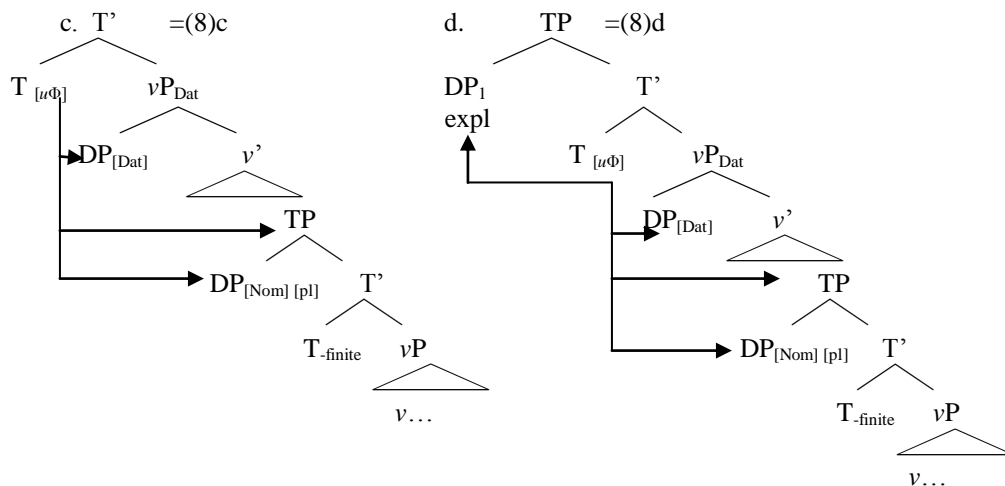

In each derivation,  $[u\Phi]$  probes every goal that “intervenes” between T and the Nominative. As such, as the number of Agree relations increases, the rate of agreement decreases. In the derivation for (8)a, shown in (10)a, two Agree relations are required in order for  $[u\Phi]$  to probe the Nominative. By contrast, in the derivation for (8)b, shown in (10)b, three Agree relations are required in order for  $[u\Phi]$  to probe the Nominative. Likewise in the derivation for (8)c, shown in (10)c, there are three Agree relations required, while in the derivation for (8)d, shown in (10)d, four Agree relations are required. Of course, the derivations shown in (10) are not the only grammatical derivations;  $[u\Phi]$  may simply fail to probe the Nominative, resulting in the default form of the verb, as illustrated in (9)b.<sup>1</sup> While I argue that case and phi features are not an indivisible bundle, I maintain the proposal that feature-checking need not force movement, thus eliminating the need for independent agreement projections. (As discussed in Section 3, Sigurðsson and Holmberg 2008, for instance, propose that Person and Number are independent projections in Icelandic.)

In addition to case and phi features probing independently, I also argue that probing is not restricted to a c-command relation between the probe and goal. A probe may Agree with a goal that occupies the specifier of the maximal projection that the probe heads. As such, I propose the Agree operation in (11).

- (11)  $\alpha$        $\beta$       Agree ( $\alpha$ ,  $\beta$ ), where  $\alpha$  is a probe and  $\beta$  is the highest matching goal in the smallest maximal projection containing  $\alpha$ , and uninterpretable features of  $\alpha$  and  $\beta$  are checked/deleted.
- 

Evidence that a probe does indeed Agree with a goal in its specifier comes from the fact agreement is more degraded in transitive expletive constructions than in the regular transitive constructions. Following Jónsson (1996), I assume that the expletive is merged in Spec,TP.<sup>2</sup> If  $[u\Phi]$  probed only its c-command domain, we would not expect agreement to be more degraded in (10)b than it is in (10)a or more degraded in (10)d than in (10)c. That agreement is more degraded in expletive constructions suggests that an additional Agree relation is required in these constructions in order for  $[u\Phi]$  to probe the Nominative. While the Agree operation proposed in (11) allows for a probe to Agree with a goal in its specifier, it does not force movement of the goal to the specifier. However, if there is a goal in the specifier, then the probe must Agree with it because it is the highest goal. Another instance of a probe agreeing with a goal in its specifier is the assignment of non-structural case, as mentioned in Section 1. For example, both Ergative and Dative are often associated with a particular theta role. Ergative subjects are usually agents, while Dative subjects are usually experiencers. Therefore, Ergative/Dative

<sup>1</sup> In Ussery 2009/2011, I argue that while Agree is obligatory, Multiple Agree (Hiraiwa 2001) is optional.

<sup>2</sup> Jónsson (1996) provides three arguments for placing the expletive in Spec,TP. While *það* appears freely in embedded clauses, embedded topicalization is quite restricted. *Það* and theta-marked subjects appear to the right of the main clause complementizer *ætti*. Topicalized items cannot appear in this position. Items can be extracted out of clauses containing *það*, but not out of clauses in which topicalization has occurred.

case is assigned to a DP that occupies the specifier of a vP whose head bears a feature specified for that case value. In the next section, I illustrate that just as case and phi features behave differently, so do phi features behave differently from each other.

### 3. Other Case-Agreement Asymmetries: Word Order Effects

As noted by Samek-Lodovici (2003), in languages that allow the subject to appear either preverbally or post-verbally, agreement either remains the same or agreement in the postverbal configuration is impoverished with respect to agreement in the preverbal configuration. Interestingly, preverbal agreement is not impoverished with respect to postverbal agreement. For instance, in Standard Arabic, finite verbs agree in person, gender, and number with pre-verbal (Nominative) subjects, as shown in (12)a. However, verbs agree in person and gender only with post-verbal subjects, as shown in (12)b.

- (12) a. L-banaat-u darab-na / \*-at l-ʔawlaad-a *Standard Arabic*  
 the-girls-Nom hit-past-3fem.pl/\*3fem.sg the-boys-Acc  
 ‘The girls hit the boys.’  
 b. Darab-at / \*-na ʔal-banaat-u Zayd-an  
 hit-past-3fem.sg / \*3fem.pl the-girls-Nom Zayd-Acc  
 ‘The girls hit Zayd.’ (Samek-Lodovici 2003, EX5)

Extending the proposal that the case and phi features are individual probes on T, I argue that the individual features can probe independently. The difference between (12)a and (12)b arises because [Nom], [Person], and [Gender] may probe either Spec,TP or the c-command domain, while [Number] can probe only Spec,TP. In (13)a, the subject moves to Spec,TP for EPP and all of the features on T Agree with it. By contrast, in (13)b, the subject does not move to Spec,TP and the directionality restrictions on [Number] prevent it from probing the subject.<sup>3</sup>

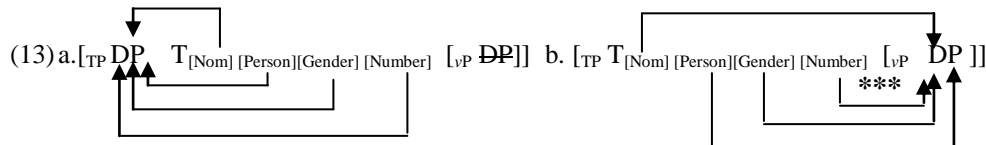

These directionality restrictions are, of course, parameterized. [Number] can certainly probe under c-command in some languages. For instance, in their analysis of the Person Restriction in Icelandic Dative-Nominative constructions, Sigurðsson and Holmberg (2008) propose that Person and Number are separate heads (with each being distinct from T) and that each probes under c-command. As shown in (1), repeated here as (14), Nominative subjects in Icelandic can be first or second person. However, first and second person Nominative objects are not allowed, as shown in (15).

- (14) a. Við tökum/\*tekur bókina. b. Þið takið/\*tekur bókina.  
 we.Nom take.1pl/3sg book-the.Acc you.Nom.pl take.2pl/3sg book.the.Acc  
 ‘We take the book.’ ‘You take the book.’ (Sigurðsson 2006)

- (15) \*Henni leiddist við/þið.  
 her.Dat bored.3sg we.Nom.pl/you.Nom.pl  
 ‘She found us/you boring.’

On Sigurðsson and Holmberg’s (2008) proposal, the Dative DP is merged lower than Person and Number, and higher than the Nominative. The crux of the analysis is grounded in derivational timing. The Dative subject moves to a position higher than the Person and Number heads. However, the Dative may move before or after those heads probe the Nominative. As shown in (16), an intervening

<sup>3</sup> See Samek-Lodovici (2003) for a detailed discussion of other languages in which post-verbal agreement is impoverished with respect to preverbal agreement, as well as an OT analysis of the phenomenon.

Dative blocks Person from probing a [1]/[2] Nominative object and the derivation crashes because the person value is not checked.

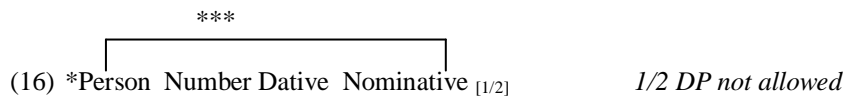

By contrast, when an intervening Dative blocks Number from probing a plural Nominative, the derivation does not crash. As shown in (17)a, an intervening Dative forces the default form to be realized. However, in (17)b the Dative does not intervene, the Number probe Agrees with the Nominative, resulting in verbal agreement.

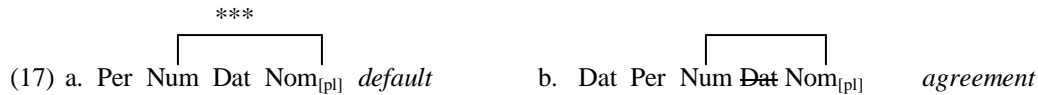

The crucial insight of Sigurðsson and Holmberg’s (2008) proposal is that the failure to check Person results in ungrammaticality, while the failure to check Number results in the default form.<sup>4</sup> In addition to illustrating that a Number probe could Agree under *c*-command, Sigurðsson and Holmberg’s (2008) analysis also highlights the fact that different phi features have different properties.

Akin to the Person Restriction in Icelandic is the well-known Person Case Constraint (PCC), originally proposed by Bonet (1991). The PCC captures the fact that in many languages, first and second person phonologically weak direct objects, i.e. clitics, cannot co-occur with phonologically weak indirect objects of any person. If there is a phonologically weak indirect object, the direct object must be third person. Interestingly, we don’t have evidence that there is an analogous restriction on number features. We do not find, for instance, constructions in which only a singular DP is allowed and a plural one is ruled out. Given the asymmetry in the distribution of DPs bearing particular features, it is reasonable to expect to find other differences between features, such as the directionality of probing.

There is another way to look at the asymmetries that hold between different types of features. In Standard Arabic, for instance, perhaps Agree simply holds under *c*-command in the syntax. T probes the Nominative DP and the DP either moves to Spec, TP for EPP or remains *v*P-internal. At the point of morphological spell-out, a rule applies that says something to the effect of “if a DP resides in Spec, TP, spell out all phi features. If a DP resides in Spec, *v*P, spell out only person and gender.” This proposal would be in line with other accounts in which case and/or agreement features are established post-syntactically. For instance, McFadden (2004/2006) argues that case is determined post-syntactically and Bobaljik (2008) and Sigurðsson (2009) argue that both types of features are determined post-syntactically. The motivation for these proposals is that since both case and agreement features are uninterpretable, they are not present in narrow syntax (agreement features are uninterpretable on T and it is debatable whether case is uninterpretable on T or on a DP, as discussed in the next section). However, all three accounts acknowledge that case and agreement are sensitive to structural relationships and locality conditions. On each proposal, an operation akin to a probe-goal relation is required; the operation simply holds at PF. Therefore, removing case and agreement from narrow syntax amounts to Agree applying post-syntactically.

While descriptively, a post-syntactic proposal captures the facts, it does not provide a motivation for deriving these facts. We do not have a reason for why preverbal agreement tends to be more fully expressed than post-verbal agreement. What we observe, though, is that probing of a specifier is less restricted than probing under *c*-command. In Standard Arabic, [Number] can only probe the specifier, and in Icelandic, [*u*Φ] necessarily probes the specifier.

#### 4. The Non-Checking of Features

Given the proposal that case and phi features are independent probes on T, we expect to find other instances in which case and agreement come apart. One such language is Warlpiri. In Warlpiri

<sup>4</sup> See Ussery 2009/2011 for a more detailed discussion of Sigurðsson and Holmberg’s (2008) proposal.

constructions with an Absolutive DP, the verb agrees with the Absolutive, as shown in (18)a. However, in (18)b there is no Nominative and the verb agrees with the Ergative.<sup>5</sup>

- (18)a. Ngaju ka-rna parnka-mi. Warlpiri  
 I.Nom pres-1sg run-nonpast  
 ‘I am running.’ (Woolford 2006b, EX 35, in Simpson 1991)
- b. Ngajulu-rlu ka-rna marlu nya-nyi  
 I-Erg pres-1sg kangaroo.Acc see-nonpast  
 ‘I see the kangaroo.’ (Woolford 2006b, EX 18)

Given the analysis in (9)a, the agreement pattern in (18)a is expected. What is not expected is the agreement pattern in (18)b. Here, the verb agrees with the Ergative DP. The Warlpiri sentence in (18)b exhibits what Legate (2008) refers to as “aggressive agreement” (p.73)<sup>6</sup>. A DP is in an agreement relationship with T, even though that DP is not in a case relationship with T. Woolford (2006b) also proposes that case and phi are divisible and argues that one feature can be deleted without being checked while another feature remains active. While in Icelandic Dative-Nominative constructions, default agreement occurs when a DP is in a case relationship, but not an agreement relationship, with T, the opposite occurs in Warlpiri. Therefore, in (11) [ $\mu\Phi$ ] probes the Ergative DP, even though [Nom] does not.

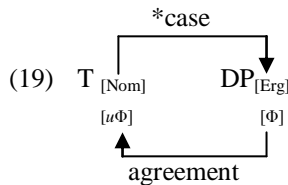

What we have seen in Icelandic, Standard Arabic, and Warlpiri is that it is possible for both case and phi features to go unchecked/unvalued, and this poses an intriguing question for checking theory: can both interpretable and uninterpretable features go unchecked? The crucial difference between interpretable and uninterpretable features is that interpretable features contribute to the meaning of the item on which they are located, while uninterpretable features do not. When a DP has the person features [1]/[2] or the number feature [pl], those features are interpretable on the DP, as they provide information to the semantics interface about the denotation of the DP. By contrast, when a verb bears the features [1]/[2] or [plural], those features do not contribute to its semantic interpretation, and are, therefore, uninterpretable on T. As outlined by Pesetsky and Torrego (2004), Agree motivates a relationship between an uninterpretable feature and its interpretable counterpart.

According to Chomsky (1995), both case and phi features on T are uninterpretable. Further, Chomsky (1995) proposes that uninterpretable features are not visible at LF and are deleted prior to the derivation converging at the semantics interface, as stated in (20).

- (20)a. Features visible at LF are accessible to the computation C<sub>HL</sub> throughout, whether checked or not.
- b. Features invisible at LF are inaccessible to C<sub>HL</sub> once checked. (Chomsky 1995, EX6)

On the analysis of Icelandic, when [ $\mu\Phi$ ] probes a Nominative, the [ $\Phi$ ] value for T is deleted prior to interpretation, while the [ $\Phi$ ] value for the Nominative remains accessible. Crucially, the statement in (20)a allows for an interpretable feature to go unchecked and still be accessible to the semantics interface, and this is precisely what happens when [ $\mu\Phi$ ] fails to probe a Nominative object. Likewise,

<sup>5</sup> Woolford (2006) assumes that Nominative and Absolutive are, essentially, the same case. Therefore, the subject of the intransitive is glossed as Nominative.

<sup>6</sup> Legate’s (2008) discussion of “aggressive agreement” is based on Hindi-Urdu constructions in which an object in an embedded clause triggers agreement on the matrix verb. In Legate’s proposal, as well as Bhatt’s (2005) analysis of these constructions, the matrix T does not assign case to the embedded object.

on the analysis of Standard Arabic, the Number on a Nominative subject goes unchecked when that DP remains  $\nu$ P-internal.

The question of whether case is interpretable is raised by Pesetsky and Torrego (2004). According to Chomsky (1995), case is uninterpretable on T and must be checked and deleted prior to convergence. However, Pesetsky and Torrego (2004) propose that structural case is uninterpretable on a DP, but interpretable on T. In particular, Pesetsky and Torrego (2004) argue that Nominative is interpreted as Tense on T. This idea is motivated in part by the proposal that uninterpretable features and their interpretable counterparts are in an Agree relation. Structural case is arguably not interpretable on a DP. While non-structural cases tend to map to thematic roles – e.g. Dative subjects tend to be experiencers and Ergative subjects tend to be agents – structural cases do not seem to adhere to thematic guidelines. On Pesetsky and Torrego’s (2004) system, therefore, Nominative is uninterpretable on a DP, as discussed in Chomsky (1995).

Constructions that lack a Nominative DP pose an intriguing challenge for checking theory. Faroese is like Icelandic and Warlpiri in having non-Nominative subjects. However, unlike Icelandic, which forces the object to be Nominative in these constructions, in Faroese, the object is Accusative, as shown in (21)a. Along similar lines, some languages exhibit a tripartite case system in which subjects of intransitives are Nominative, while subjects of transitives are Ergative and objects are Accusative. The Thangu sentence in (21)b exhibits an Ergative-Accusative case pattern.

- |         |  |                |
|---------|--|----------------|
| (21) a. | Mær líkar henda filmin.<br>me.Dat likes this film.Acc<br>'I like this film.' | <i>Faroese</i> |
|         | (Woolford 2006b, EX 4, from Barnes 1986)                                     |                |
| b.      | Yūljū-Tu taykka-Na pūyan.<br>man-Erg woman-Acc hit<br>'Man hit woman.'       | <i>Thangu</i>  |
|         | (Woolford 2006b, EX 7, from Schebeck 1976)                                   |                |

The constructions in (21) are like intransitive constructions with Dative subjects in Icelandic: there is no Nominative (or Absolutive) DP. The Nominative feature on T, then, goes unchecked, as noted by Legate (2008) and Woolford (2006b). If Nominative is, indeed, interpretable, then constructions such as (21) parallel those in which [ $\Phi$ ], which is interpretable on a DP, goes unchecked.

However, it is not completely clear that Nominative is interpretable as Tense on T, in large part, because Nominative does not map to some particular value for tense. Nominative is not interpreted as [present] or [past], for instance. It may be that Nominative is uninterpretable on both T and a DP, which would mean that an Agree relation can hold between two uninterpretable features, contra Pesetsky and Torrego (2004). We would then need to motivate the Agree relation between these features. Perhaps a sufficient motivation would be that a DP with an unvalued case feature is required to be in an Agree relation with a head that has a valued case feature, irrespective of interpretability. This would mark another difference between case and agreement. Agreement is established between a probe that has uninterpretable features and a goal that has interpretable features. I leave open the question of whether Nominative is interpretable on T. If it is, then it patterns like [ $u\Phi$ ] in that it may go unchecked.

## 5. Conclusion

I have shown that case and phi features are not an indivisible feature bundle. While the general pattern is that case and agreement travel together, there are well-established instances in which case and agreement come apart. In order to account for the asymmetries between case and agreement and the asymmetries between individual agreement features, I have argued that phi features on T probe independently of the case feature on T. Additionally, I have provided evidence that probing is not restricted to a c-command and I proposed a revised definition of Agree which allows for probing to occur either under c-command or in a spec-head configuration. The consequence of allowing case and phi features to probe independently is that a feature may be deleted without being checked, while other features remain active and enter into Agree relations.



## References

- Bhatt, Rajesh. 2005. Long distance agreement in Hindi-Urdu. *NLLT* 23:757–807.
- Bobaljik, Jonathan and Susi Wurmbrand. 2005. The domain of agreement. *NLLT* 23.4: 809-865.
- Bobaljik, Jonathan. 2008. Where's phi? Agreement as a post-syntactic operation. In D. Adger, S. Béjar, and D. Harbour, eds., *Phi-Theory: Phi features across interfaces and modules*, 295-328. Oxford University Press.
- Bonet, Eulalia. 1991. Morphology after syntax: Pronominal clitics in Romance. Doctoral dissertation, MIT, Cambridge, MA.
- Chomsky, Noam. 1991. Some notes on economy of derivation and representation. In Robert Freidin, ed. *Principles and Parameters in Comparative Grammar*, 417-454. Cambridge, MA: MIT Press.
- Chomsky, Noam. 1995. *The Minimalist Program*. Cambridge, MA: MIT Press.
- Chomsky, Noam. 2000. Minimalist inquiries: the framework. In R. Martin, D. Michaels, and J. Uriagereka, eds., *Step by step: essays on minimalist syntax in honor of Howard Lasnik*, 89-155. Cambridge, MA: MIT Press.
- Chomsky, Noam. 2001. Derivation by phase. In *Ken Hale: A life in language*, ed. Michael Kenstowicz. Cambridge, Mass.: MIT Press.
- Hiraiwa, Ken. 2001. Multiple agree and the defective intervention constraint in Japanese. In Ora Matsushansky et al., eds., *The Proceedings of the MIT-Harvard Joint Conference (HUMIT 2000)* 40: 67-80. Cambridge, MA: MITWPL.
- Jónsson, Jóhannes Gísli. 1996. Clausal architecture and case in Icelandic, Ph.D. Dissertation, University of Massachusetts, Amherst, MA. [Distributed by GLSA].
- Legate, Julie Anne. 2008. Morphological and abstract case. *LI* 39(1):55-101.
- McFadden, Thomas. 2004. The position of morphological case in the derivation: a study on the syntax-morphology interface. Doctoral dissertation, University of Pennsylvania, Philadelphia, PA.
- McFadden, Thomas. 2006. Default case and the status of compound categories in Distributed Morphology. In *Proceedings of the 30th annual Penn Linguistics Colloquium*. Available at <http://ling.auf.net/lingBuzz/000323>.
- Pesetsky, David and Esther Torrego. 2004. Tense and the nature of syntactic categories. In *The Syntax of Time*, ed. by Jacqueline Gueron and Jacqueline Lecarme. Cambridge, MA: MIT Press.
- Samek-Lodovici, Vieri. 2003. Agreement Impoverishment under Subject Inversion – A Cross-linguistic Analysis. In G. Fanselow, and C. Féry, eds., *Resolving Conflicts in Grammar*. Linguistische Berichte Sonderheft 11:49-82.
- Sigurðsson, Halldór Ármann. 2006. Agree in syntax, agreement in signs. In Cedric Boeckx, ed., *Agreement Systems*, 201–237.
- Sigurðsson, Halldór Ármann. 2009. Remarks on features. In Kleanthes K. Grohmann, ed., *Explorations of Phase Theory: Features and Arguments*, 21-52. Berlin: Mouton de Gruyter.
- Sigurðsson, Halldór Ármann and Anders Holmberg. 2008. Icelandic dative intervention: person and number are separate probes. In Roberta D'Alessandro, ed. *Agreement Restrictions*, 251-280. Berlin: Mouton de Gruyter.
- Ussery, Cherlon. 2009. *Optionality and Variability: Syntactic Licensing Meets Morphological Spell-Out*. Doctoral dissertation, University of Massachusetts, Amherst, MA.
- Ussery, Cherlon. 2011. Variability in Icelandic agreement: An interaction of DP licensing and Multiple Agree. *Proceedings of NELS 40*, Robert Staubs, et al., eds. University of Massachusetts, Amherst, MA. [Distributed by GLSA].
- Woolford, Ellen. 2006a. Lexical case, inherent case, and argument structure. *LI* 37(1): 111-130.
- Woolford, Ellen. 2006b. Case-Agreement Mismatches. In Cedric Boeckx ed. *Agreement Systems*, 317-339. John Benjamins.
- Wurmbrand, Susi. 2006. Licensing Case. *Journal of Germanic Linguistics* 18(3):175-236.